

THERMOPLASTIC FLANGES



TECHNICAL INFORMATION WEIGHTS & DIMENSIONS

February 1, 2011

SUPERSEDES ALL PREVIOUS EDITIONS



Quality Systems Certificate No. 293
Corporate Facilities, Sylmar, CA
Assessed to ISO 9001: 2008

Visit our web site

www.spearsmfg.com

FL-4-0211

Additional Technical Publications

THERMOPLASTIC VALVES • PRODUCT GUIDE & ENGINEERING SPECIFICATIONS	V-4
ACTUATED VALVES • PRODUCT GUIDE & ENGINEERING SPECIFICATIONS	AV-4
PVC SCHEDULE 40 FITTINGS • WEIGHTS & DIMENSIONS	40-4
PVC SCHEDULE 80 FITTINGS • WEIGHTS & DIMENSIONS	80-4
CPVC CTS FITTINGS & VALVES • WEIGHTS & DIMENSIONS	CTS-4
PVC INSERT FITTINGS • WEIGHTS & DIMENSIONS	INS-4
PVC DWV FITTINGS • TECHNICAL INFORMATION	MDWV-4
CPVC LABWASTE™ FITTINGS • TECHNICAL INFORMATION & INSTALLATION GUIDE.	LW-4
LXT VALVES & FITTINGS • WEIGHTS & DIMENSIONS	LXT-4

Contents

Page

GENERAL INFORMATION

Recommendations For Installers And Users	1
Bolt Kit Selection Guide	2
Bolt Torque	2
Torque Sequence	2
Gaskets	3
Gasket Selection Guide	3
Flange Make-Up	3
Configuration Terminology	3

PVC & CPVC INJECTION MOLDED CLASS 150 FLANGES

Technical Information

Application	4
Pressure Ratings	4
Flange Types	4
Materials	4
Conformance Standards	4
Weights & Dimensions	4
Dimension References	4

PVC & CPVC FABRICATED IPS, PIP AND CLASS 300 FLANGES

Technical Information

Application	12
Pressure Ratings	12
Flange Types	12
Special Note on PIP Flange Sizes	12
Materials	12
Conformance Standards	12
Weights & Dimensions	13

The information contained in this publication is based on current information and product design at the time of publication and is subject to change without notification. Our ongoing commitment to product improvement may result in some variations. No representations, guarantees or warranties of any kind are made as to its accuracy, suitability for particular application or results to be obtained therefrom. For verification of technical data or additional information not contained herein, please contact Spears® Technical Services Department [West Coast: (818) 364-1611 — East Coast: (678) 985-1263].

THERMOPLASTIC FLANGES



GENERAL INFORMATION

Recommendations For Installers And Users

Plastic piping systems should be **ENGINEERED, INSTALLED, and OPERATED** in accordance with **ESTABLISHED DESIGN AND ENGINEERING STANDARDS AND PROCEDURES** for plastic piping systems. Suitability for the intended service application should be determined by the installer and /or user prior to installation of a plastic piping system. **PRIOR TO ASSEMBLY, all piping system components should be inspected for damage or irregularities. Mating components should be checked to assure that tolerances and engagements are compatible. Do not use any components that appear irregular or do not fit properly. Contact the appropriate manufacturer of the component product in question to determine usability.**

WARNING: Spears® Manufacturing Company **DOES NOT RECOMMEND** the use of thermoplastic piping products for systems to transport or store compressed air or gases, or the testing of thermoplastic piping systems with compressed air or gases in above-and-below-ground locations. The use of Spears® products in compressed air or gas systems automatically voids Spears® warranty for such products, and their use against our recommendation is entirely the responsibility and liability of the installer. Spears® Manufacturing Company will not accept responsibility for damage or impairment of its products, or other consequential or incidental damages caused by misapplication, incorrect assembly, and/or exposure to harmful substances or conditions.

Solvent Weld Connections — Use quality solvent cements and primers formulated for the intended service application, pipe size and type of joint. While the pipe and fitting materials may be compatible with the intended medium, the solvent cement may not be. Consult the manufacturer for suitability of use. Read and follow the cement and primer manufacturers' applications and cure time instructions thoroughly. Be sure to use the correct size applicator.

Threaded Connections — Use a quality grade thread sealant. **WARNING: SOME PIPE JOINT COMPOUNDS OR TEFLON® PASTES MAY CONTAIN SUBSTANCES THAT COULD CAUSE STRESS CRACKING TO PLASTIC.** Spears® Manufacturing Company recommends the use of Spears® Blue 75™ thread sealant which has been tested for compatibility with Spears® products. Please follow the sealant manufacturer's application/installation instructions. Choice of an appropriate thread sealant other than those listed above is at the discretion of the installer. 1 to 2 turns beyond **FINGER TIGHT** is generally all that is required to make a sound plastic thread connection. Unnecessary **OVERTIGHTENING** will cause **DAMAGE TO BOTH PIPE AND FITTING.**



THERMOPLASTIC FLANGES

Bolt Kit Selection Guide

Bolt Hardware Kits Available
For Connection of 2-Spears® Flanges
Includes Bolts, Nuts & Flat Washers for Specified Flange Size

Order Gaskets & Bolt Kits Separately

- Pre-coated, Anti-seize Lubricated Bolts
- Available in Zinc Coated Steel, Type 316 Stainless Steel or Type 304 Stainless Steel

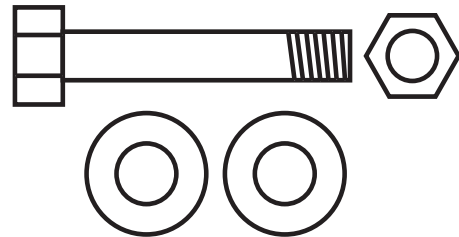

Flange Size	Bolts* Per Kit	Diameter (in.-TPI)	Length (in.)	Zinc	Kit Part Number	
					316 SS	304 SS
1/2 & 3/4	4	1/2 - 13	2	HK-005	HK1-005	HK2-005
1 & 1-1/4	4	1/2 - 13	2-1/4	HK-010	HK1-010	HK2-010
1-1/2	4	1/2 - 13	2-1/2	HK-015	HK1-015	HK2-015
2	4	5/8 - 11	3	HK-020	HK1-020	HK2-020
2-1/2	4	5/8 - 11	3-1/4	HK-025	HK1-025	HK2-025
3	4	5/8 - 11	3-1/2	HK-030	HK1-030	HK2-030
4	8	5/8 - 11	3-1/2	HK-040	HK1-040	HK2-040
5 & 6	8	3/4 - 10	4	HK-060	HK1-060	HK2-060
8	8	3/4 - 10	4-1/2	HK-080	HK1-080	HK2-080
10 & 12	12	7/8 - 9	5	HK-120	HK1-120	HK2-120

* Each Bolt Includes Nut & Two (2) Flat Washers

Bolt Torque

Recommended Bolt Torque is shown in Table 1. Threads should be clean and well lubricated. Actual field conditions may require variations in these recommendations. **CAUTION: UNNECESSARY OVER TORQUING WILL DAMAGE THE FLANGE.**

Table 1

Flange Size (in.)	Recommended Torque (ft. lbs.)
1/2 - 1-1/2	12
2 - 4	25
5	30
6 - 8	40
10	64
12	95
14 - 24	110

Torque Sequence

Bolt Torque sequence is shown Below in Table 2.

Table 2

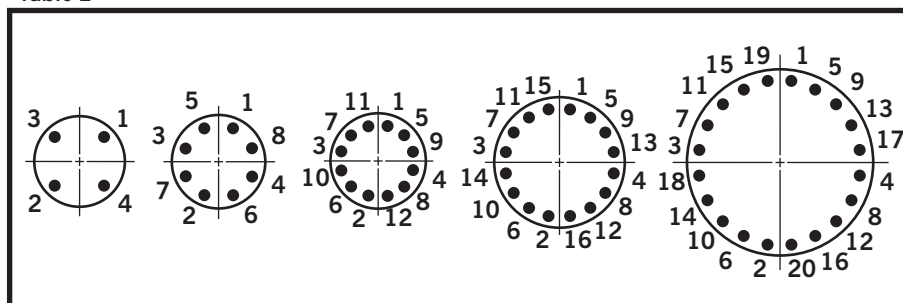

THERMOPLASTIC FLANGES



Gaskets

Full faced, 1/8" thick elastomer gaskets with a Shore "A" Durometer of approximately 70 is recommended.

Gasket Selection Guide

Following Gasket Numbers Available from Spears®

Order Gaskets & Bolt Kits Separately

- 1/8" Full-Face design with ANSI Class 150 Bolt Patterns
- Pressure rated to 150 psi @ 73°F
- Available in Buna-N, EPDM, or Viton® (FKM)

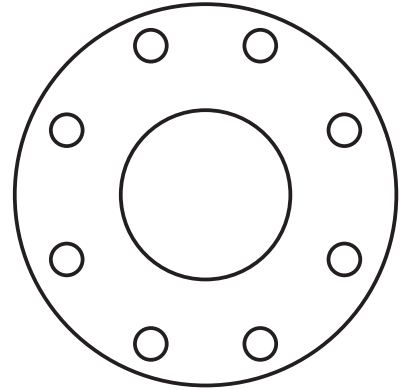

Flange Size	Bolts Per Kit	Gasket Part Number		
		Buna-N	EPDM	FKM
1/2	4	GK1-005	GK2-005	GK3-005
3/4	4	GK1-007	GK2-007	GK3-007
1	4	GK1-010	GK2-010	GK3-010
1-1/4	4	GK1-012	GK2-012	GK3-012
1-1/2	4	GK1-015	GK2-015	GK3-015
2	4	GK1-020	GK2-020	GK3-020
2-1/2	4	GK1-025	GK2-025	GK3-025
3	4	GK1-030	GK2-030	GK3-030
4	8	GK1-040	GK2-040	GK3-040
5	8	GK1-050	GK2-050	GK3-050
6	8	GK1-060	GK2-060	GK3-060
8	8	GK1-080	GK2-080	GK3-080
10	12	GK1-100	GK2-100	GK3-100
12	12	GK1-120	GK2-120	GK3-120

Flange Make-up

Once a flange is joined to pipe, the method for joining two flanges is as follows:

1. Piping runs joined to the flanges must be installed in a straight line position to the flange to avoid stress at the flange due to misalignment. Piping must also be secured and supported to prevent lateral movement which can create stress and damage the flange.
2. With gasket in place, align the bolt holes of the mating flanges by rotating the ring into position.
3. Insert all bolts, washers (two standard flat washers per bolt), and nuts.
4. Make sure the faces of the mating surfaces are flush against gasket prior to bolting down the flanges.
5. Tighten the nuts by hand until they are snug. Establish uniform pressure over the flange face by tightening the bolts in 5 ft.-lbs. increments according to the sequence shown in Table 2 following a 180° opposing sequence.
6. Care must be taken to avoid "bending" the flange when joining a Spears® flange to a "raised face" flange, or a wafer-style valve. Do not use bolts to bring together improperly mated flanges.

Configuration Terminology

Multi-Bolt Pattern Ring — Bolt hole drilling accepts ANSI and Metric Flanges

Socket — Slip socket connection for solvent cement welding

Spigot — Pipe O.D. connection for solvent welding

Fipt — Female Iron Pipe Thread

SR Fipt — Spears® patented Special Reinforced (SR) plastic thread

IPS — Iron Pipe Size

PIP — Plastic Irrigation Pipe



PVC & CPVC INJECTION MOLDED CLASS 150 FLANGES

Technical Information

Application

Molded CLASS 150 Flange fittings are coupling devices designed for joining IPS (Iron Pipe Size) plastic piping systems, where frequent disassembly may be required, and can be used as a transitional fitting for joining plastic to metal piping systems. Suitability of application is at the discretion of the user.

Pressure Rating

150 psi, water at 73°F.

Flange Types

One Piece — Available in socket configuration, sizes 1/2" through 8"; threaded and SR threaded (Special Reinforced) configuration sizes 1/2" through 4".

Van Stone Style — Two-piece design with rotating flange ring, available in socket configurations, sizes 1/2" through 16"; threaded configurations, sizes 1/2" through 4" and spigot configurations, sizes 1/2" through 12".

Blind — Closed ring design for capping off a mating flange, flanged fitting or flanged valve, available in sizes 1/2" through 12".

Materials

All injection molded flanges are produced from either PVC or CPVC materials approved for potable water use by the National Sanitation Foundation (NSF).

Glass-filled PVC or CPVC materials may be used in certain Van Stone Style flange rings and large diameter Blind flanges where additional reinforcement is deemed necessary.

Conformance Standards

Socket & Spigot — ASTM D 2467 (PVC); ASTM F 439 (CPVC), as applicable.

Threads — ASTM F 1498.

Bolt Hole Pattern — ANSI B16.5; ASTM D 4024.

Material — ASTM D 1784 (PVC Cell Classification 12454-B, CPVC Cell Classification 23447-B).

Weights & Dimensions

Specified minimum bolt lengths are based on the use of two Spears® Flanges, two standard flat washers, standard nut and 1/8" thick elastomer full face gasket. Mating with other brands or accessories may require variation. Bolts and gaskets are not supplied with flanges.

Dimension references:

L = Overall length of hub, $\pm 1/16$ inch.

M = Outside diameter of socket hub, $\pm 1/16$ inch.

N = (Laying Length) socket/spigot bottom to seal-ring face of flange, $\pm 1/16$ inch.

R = Height (thickness) of flange ring, $\pm 1/16$ inch.

Max O.D. = Outside diameter of ring, $\pm 1/16$ inch.

Bolt Circle Diameter = ANSI B 16.5 Standard; ASTM D 4024, $\pm 1/16$ inch.

PVC & CPVC INJECTION MOLDED CLASS 150 FLANGES



Flange One Piece

Socket

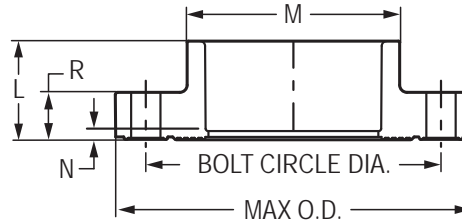

Part Number		Size	L	M	N	R	Bolt Circle Dia.	No. of Bolt Holes	Bolt Size	Min. Bolt Length	Max O.D.	Approx. Wt. (Lbs.)	
PVC	CPVC											PVC	CPVC
851-005	851-005C	1/2	1-1/16	1-9/32	1/8	9/16	2-3/8	4	1/2	2	3-1/2	.22	.24
851-007	851-007C	3/4	1-3/16	1-1/2	1/8	5/8	2-3/4	4	1/2	2	3-7/8	.31	.31
851-010	851-010C	1	1-5/16	1-13/16	3/16	3/4	3-1/8	4	1/2	2-1/4	4-1/4	.44	.47
851-012	851-012C	1-1/4	1-7/16	2-7/32	3/16	23/32	3-1/2	4	1/2	2-1/4	4-5/8	.41	.42
851-015	851-015C	1-1/2	1-23/32	2-1/2	1/4	3/4	3-7/8	4	1/2	2-1/2	5	.61	.64
851-020	851-020C	2	1-27/32	3	5/16	27/32	4-3/4	4	5/8	3	6	.82	.95
851-025	851-025C	2-1/2	2-1/4	3-1/2	1/2	1	5-1/2	4	5/8	3-1/4	7	1.63	1.67
851-030	851-030C	3	2-5/16	4-9/32	3/8	1-1/16	6	4	5/8	3-1/4	7-1/2	1.74	1.81
851-040	851-040C	4	2-7/16	5-7/32	3/16	1-5/32	7-1/2	8	5/8	3-1/2	9-1/16	2.67	2.78
851-050	851-050C	5	3-1/4	6-3/8	1/4	1	8-1/2	8	3/4	3-3/4	10-1/8	3.00	3.17
851-060	851-060C	6	3-1/4	7-9/16	1/4	1-3/8	9-1/2	8	3/4	4	11	4.06	4.34
851-080	851-080C	8	4-9/16	9-3/4	9/16	1-7/16	11-3/4	8	3/4	4-1/2	13-1/2	7.63	7.36
851-100F	851-100CF	10	9-7/8	11-15/16	5-5/8	1-1/4	14-1/4	12	7/8	---	16	18.90	19.27
851-120F	851-120CF	12	10-11/16	14-1/8	4-7/16	1-3/8	17	12	7/8	---	19	26.92	30.67

Flange One Piece

Flt

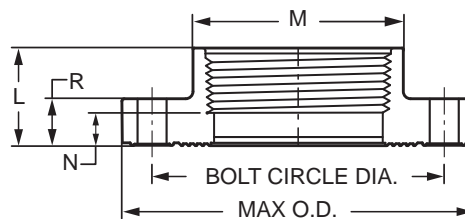

Part Number		Size	L	M	N	R	Bolt Circle Dia.	No. of Bolt Holes	Bolt Size	Min. Bolt Length	Max O.D.	Approx. Wt. (Lbs.)	
PVC	CPVC											PVC	CPVC
852-005	852-005C	1/2	1-1/16	1-5/16	9/32	9/16	2-3/8	4	1/2	2	3-1/2	.21	.22
852-007	852-007C	3/4	1-3/16	1-17/32	15/32	5/8	2-3/4	4	1/2	2	3-7/8	.30	.32
852-010	852-010C	1	1-5/16	1-13/16	7/16	3/4	3-1/8	4	1/2	2-1/4	4-1/4	.41	.48
852-012	852-012C	1-1/4	1-3/8	2-7/32	17/32	23/32	3-1/2	4	1/2	2-1/4	4-5/8	.44	.46
852-015	852-015C	1-1/2	1-3/4	2-1/2	19/32	3/4	3-7/8	4	1/2	2-1/2	5	.64	.74



PVC & CPVC INJECTION MOLDED CLASS 150 FLANGES

Flange One Piece (continued)

Fipt

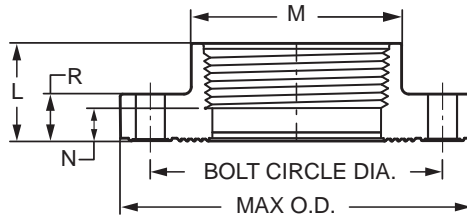

Part Number		Size	L	M	N	R	Bolt Circle Dia.	No. of Bolt Holes	Bolt Size	Min. Bolt Length	Max O.D.	Approx. Wt. (Lbs.)	
PVC	CPVC											PVC	CPVC
852-020	852-020C	2	1-27/32	3	7/8	7/8	4-3/4	4	5/8	3	6	.96	1.00
852-025	852-025C	2-1/2	2-1/4	3-1/2	15/16	1	5-1/2	4	5/8	3-1/4	7	1.65	1.41
852-030	852-030C	3	2-5/16	4-9/32	29/32	1-1/16	6	4	5/8	3-1/4	7-1/2	1.83	1.91
852-040	852-040C	4	2-1/16	5-7/16	5/16	1-1/4	7-1/2	8	5/8	3-1/2	9	2.79	2.86
852-050F	852-050CF	5	6-5/8	6-1/8	5-1/4	1-5/16	8-1/2	8	3/4	---	10-1/8	5.25	5.51
852-060F	852-060CF	6	6-15/16	7-1/4	5-1/2	1-5/16	9-1/2	8	3/4	4	11	7.16	7.69
852-080F	852-080CF	8	8-9/16	9-7/16	6-15/16	1-7/16	11-3/4	8	3/4	4-1/2	13-1/2	13.41	13.92
852-100F	852-100CF	10	7-3/8	11-3/4	5-1/2	1-3/8	14-1/4	12	7/8	5	16	20.65	20.72
852-120F	852-120CF	12	7	13-15/16	5	1-1/2	17	12	7/8	---	19	21.79	22.59

Special Reinforced Flange One Piece

SR Fipt

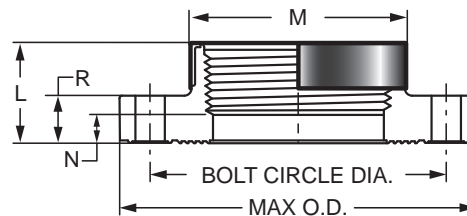

Part Number		Size	L	M	N	R	Bolt Circle Dia.	No. of Bolt Holes	Bolt Size	Min. Bolt Length	Max O.D.	Approx. Wt. (Lbs.)	
PVC	CPVC											PVC	CPVC
852-005SR	852-005CSR	1/2	1-3/32	1-7/32	11/32	9/16	2-3/8	4	1/2	2	3-1/2	.20	.22
852-007SR	852-007CSR	3/4	1-3/16	1-3/8	7/16	5/8	2-3/4	4	1/2	2	3-7/8	.27	.30
852-010SR	852-010CSR	1	1-7/16	1-23/32	17/32	21/32	3-1/8	4	1/2	2-1/4	4-1/4	.37	.39
852-012SR	852-012CSR	1-1/4	1-9/16	2-1/16	19/32	21/32	3-1/2	4	1/2	2-1/4	4-5/8	.49	.52
852-015SR	852-015CSR	1-1/2	1-3/4	2-7/16	3/4	3/4	3-7/8	4	1/2	2-1/2	5	.63	.67
852-020SR	852-020CSR	2	1-13/16	3-1/32	13/16	13/16	4-3/4	4	5/8	3	5-31/32	.99	1.04
852-025SR	852-025CSR	2-1/2	2-1/8	3-19/32	3/8	1	5-1/2	4	5/8	3-1/4	7	1.58	1.69
852-030SR	852-030CSR	3	2-5/16	4-9/32	27/32	1-1/16	6	4	5/8	3-1/4	7-1/2	1.79	1.97
852-040SR	852-040CSR	4	2-1/2	5-1/4	1	1-5/32	7-1/2	8	5/8	3-1/2	9	2.74	2.89

PVC & CPVC INJECTION MOLDED CLASS 150 FLANGES



BLIND FLANGE

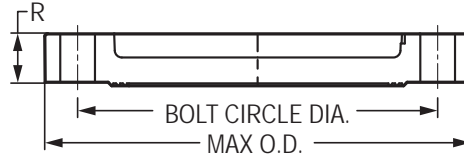

Part Number		Size	R	Bolt Circle Dia.	No. of Bolt Holes	Bolt Size	Min. Bolt Length	Max. O.D.	Approx. Wt. (Lbs.)	
PVC	CPVC								PVC	CPVC
853-005	853-005C	1/2	9/16	2-3/8	4	1/2	2	3-1/2	.21	.21
853-007	853-007C	3/4	5/8	2-3/4	4	1/2	2	3-7/8	.28	.30
853-010	853-010C	1	3/4	3-1/8	4	1/2	2-1/4	4-1/4	.41	.47
853-012	853-012C	1-1/4	23/32	3-1/2	4	1/2	2-1/4	4-5/8	.37	.40
853-015	853-015C	1-1/2	3/4	3-7/8	4	1/2	2-1/2	5	.62	.64
853-020	853-020C	2	27/32	4-3/4	4	5/8	3	5-31/32	.82	.88
853-025	853-025C	2-1/2	1	5-1/2	4	5/8	3-1/4	7	1.61	1.63
853-030	853-030C	3	1-1/16	6	4	5/8	3-1/4	7-5/8	1.56	1.64
853-040	853-040C	4	1-5/32	7-1/2	8	5/8	3-1/2	9-1/16	2.42	2.98
853-060	853-060C	6	1-3/8	9-1/2	8	3/4	4	11	4.36	4.45
853-080	853-080C	8	1-7/16	11-3/4	8	3/4	4-1/2	13-1/2	6.83	7.20
853-100	853-100C	10	1-11/16	14-1/4	12	7/8	5	16	11.32	11.80
853-120	853-120C	12	1-11/16	17	12	7/8	5	19	15.49	17.20

Flange Van Stone Style

(Two Piece)

Socket

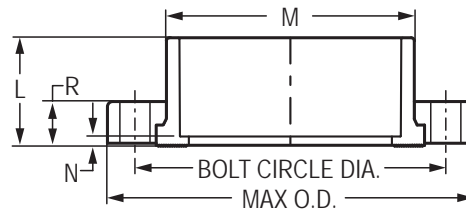

Part Number		Size	L	M	N	R	Bolt Circle Dia.	No. of Bolt Holes	Bolt Size	Min. Bolt Length	Max O.D.	Approx. Wt. (Lbs.)	
PVC	CPVC											PVC	CPVC
854-005	854-005C	1/2	1-1/32	1-7/32	5/32	17/32	2-3/8	4	1/2	2	3-1/2	.19	.20
854-007	854-007C	3/4	1-1/8	1-7/16	5/32	9/16	2-3/4	4	1/2	2	3-7/8	.26	.27
854-010	854-010C	1	1-9/32	1-3/4	5/32	5/8	3-1/8	4	1/2	2-1/4	4-1/4	.36	.37
854-012	854-012C	1-1/4	1-13/32	2-5/32	5/32	11/16	3-1/2	4	1/2	2-1/4	4-5/8	.46	.45
854-015	854-015C	1-1/2	1-17/32	2-7/16	3/16	3/4	3-7/8	4	1/2	2-1/2	5	.56	.60
854-020	854-020C	2	1-11/16	2-15/16	3/16	13/16	4-3/4	4	5/8	3	6	.85	.91



PVC & CPVC INJECTION MOLDED CLASS 150 FLANGES

Flange Van Stone Style (continued)

(Two Piece)
Socket

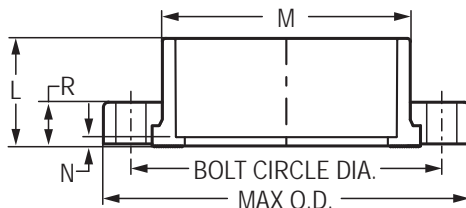

Part Number		Size	L	M	N	R	Bolt Circle Dia.	No. of Bolt Holes	Bolt Size	Min. Bolt Length	Max O.D.	Approx. Wt. (Lbs.)	
PVC	CPVC											PVC	CPVC
854-025	854-025C	2-1/2	2	3-1/2	3/16	31/32	5-1/2	4	5/8	3-1/4	7	1.40	1.40
854-030	854-030C	3	2-1/8	4-1/4	1/4	1-1/16	6	4	5/8	3-1/4	7-1/2	1.66	1.70
854-040	854-040C	4	2-1/2	5-1/4	1/4	1-1/8	7-1/2	8	5/8	3-1/2	9	2.68	2.84
854-050	854-050C	5	3	6-1/4	3/8	1-1/8	8-1/2	8	3/4	3-3/4	10-1/8	3.35	3.60
854-060	854-060C	6	3-3/8	7-9/16	7/16	1-9/32	9-1/2	8	3/4	4	11	4.54	4.67
854-080	854-080C	8	4-3/8	9-5/16	9/32	1-3/8	11-3/4	8	3/4	4-1/2	13-1/2	6.69	7.06
854-100	854-100C	10	5-11/16	11-3/4	21/32	1-5/8	14-1/4	12	7/8	5	16	11.45	11.76
854-120	854-120C	12	7-1/4	13-3/4	5/8	1-1/2	17	12	7/8	5	19	16.78	18.50
854-140	854-140C	14	7-1/2	15-1/2	1/2	2	18-3/4	12	1	5-1/2	21	26.84	28.42
854-160	854-160C	16	8-3/4	17-3/4	3/4	2-3/8	21-1/4	16	1	6-1/2	23-1/2	37.64	24.81
854-180	854-180C	18	9	20	1/4	2-3/8	22-3/4	16	1-1/8	6-1/2	25	45.33	46.48

Flange Van Stone Style

with Plastic Solid Ring

(Two Piece)
Socket

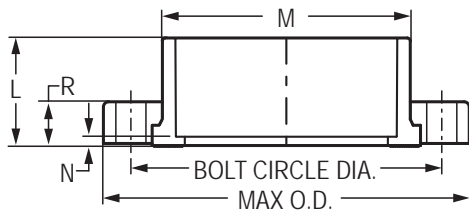

Part Number		Size	L	M	N	R	Bolt Circle Dia.	No. of Bolt Holes	Bolt Size	Min. Bolt Length	Max O.D.	Approx. Wt. (Lbs.)	
PVC	CPVC											PVC	CPVC
S854-020	---	2	1-11/16	2-15/16	3/16	13/16	4-3/4	4	5/8	3	6	.85	---
S854-030	S854-030C	3	2-1/8	4-1/4	1/4	1-1/16	6	4	5/8	3-1/4	7-1/2	1.66	1.70
S854-040	S854-040C	4	2-1/2	5-1/4	1/4	1-1/8	7-1/2	8	5/8	1/2	9	3.02	2.84
S854-060	S854-060C	6	3-3/8	7-9/16	7/16	1-9/32	9-1/2	8	3/4	4	11	4.54	4.67

PVC & CPVC INJECTION MOLDED CLASS 150 FLANGES



Flange Van Stone Style (continued)

with Plastic Solid Ring
(Two Piece)
Socket

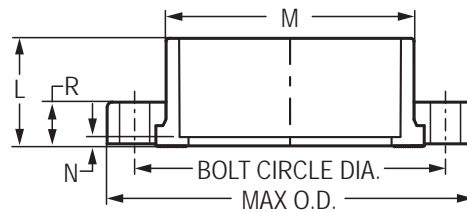

Part Number		Size	L	M	N	R	Bolt Circle Dia.	No. of Bolt Holes	Bolt Size	Min. Bolt Length	Max O.D.	Approx. Wt. (Lbs.)	
PVC	CPVC											PVC	CPVC
S854-080	S854-080C	8	4-3/8	9-5/16	3/8	1-3/8	11-3/4	8	3/4	4-1/2	13-1/2	6.69	7.06
S854-100	S854-100C	10	5-11/16	11-3/4	11/16	1-5/8	14-1/4	12	7/8	5	16	11.69	11.76
S854-120	S854-120C	12	7-1/4	13-3/4	5/8	1-3/4	17	12	7/8	5	19	16.78	19.13

Flange Van Stone Style

with Multi-Bolt Pattern Ring
(Two Piece)
Socket

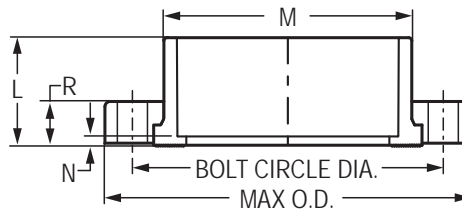

Part Number		Size	L	M	N	R	Bolt Circle Dia.		No. of Bolt Holes	Bolt Size	Max O.D.	Approx. Wt. (Lbs.)	
PVC	CPVC						Min	Max				PVC	CPVC
M854-020	M854-020C	2	1-11/16	2-15/16	3/16	13/16	4-1/2	4-15/16	4	5/8	6	.85	.93
M854-060	M854-060C	6	3-3/8	7-9/16	7/16	1-9/32	9-7/32	9-1/2	8	3/4	11	4.80	5.09
M854-080	M854-080C	8	4-3/8	9-5/16	3/8	1-3/8	11-1/2	11-3/4	8	3/4	13-1/2	6.69	7.21



PVC & CPVC INJECTION MOLDED CLASS 150 FLANGES

Flange Van Stone Style

(Two Piece)

Fipt

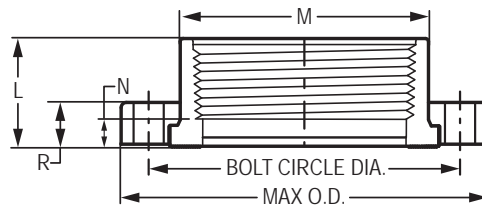

Part Number		Size	L	M	N	R	Bolt Circle Dia.	No. of Bolt Holes	Bolt Size	Min. Bolt Length	Max. O.D.	Approx. Wt. (Lbs.)	
PVC	CPVC											PVC	CPVC
855-005	855-005C	1/2	1-1/32	1-7/32	9/32	17/32	2-3/8	4	1/2	2	3-1/2	.19	.20
855-007	855-007C	3/4	1-5/32	1-3/8	13/32	9/16	2-3/4	4	1/2	2	3-7/8	.27	.28
855-010	855-010C	1	1-1/4	1-3/4	5/16	5/8	3-1/8	4	1/2	2-1/4	4-1/4	.36	.39
855-012	855-012C	1-1/4	1-3/8	2-1/8	13/32	11/16	3-1/2	4	1/2	2-1/4	4-5/8	.46	.47
855-015	855-015C	1-1/2	1-15/32	2-7/16	13/32	3/4	3-7/8	4	1/2	2-1/2	5	.55	.61
855-020	855-020C	2	1-9/16	2-31/32	1/2	13/16	4-3/4	4	5/8	3	6	.87	.94
855-025	855-025C	2-1/2	2	3-9/16	7/16	1	5-1/2	4	5/8	3-1/4	7	1.22	1.50
855-030	855-030C	3	2-1/8	4-1/4	1/2	1-1/16	6	4	5/8	3-1/4	7-1/2	1.73	1.79
855-040	855-040C	4	2-1/16	5-1/4	3/8	1-1/4	7-1/2	8	5/8	3-1/2	9	2.61	2.78
855-060F	855-060CF	6	6-3/8	7-3/16	4-15/16	1-1/4	9-1/2	8	3/4	4	11	7.62	7.69
855-080F	855-080CF	8	8-1/8	9-5/16	6-7/16	1-1/2	11-3/4	8	3/4	4-1/2	13-1/2	12.84	13.92
855-100F	855-100CF	10	10-3/8	11-9/16	8-9/16	1-11/16	14-1/4	12	7/8	5	16	20.65	20.72
855-120F	855-120CF	12	11-13/16	13-3/4	9-3/4	1-5/8	17	12	7/8	5	19	33.52	34.00

Flange Van Stone Style

(Two Piece)

Spigot

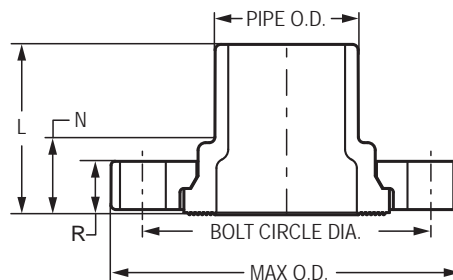

Part Number		Size	L	N	R	Bolt Circle Dia.	No. of Bolt Holes	Bolt Size	Min. Bolt Length	Max. O.D.	Approx. Wt. (Lbs.)	
PVC	CPVC										PVC	CPVC
856-005	856-005C	1/2	1-3/4	29/32	17/32	2-3/8	4	1/2	2	3-1/2	.20	.21
856-007	856-007C	3/4	1-15/16	31/32	9/16	2-3/4	4	1/2	2	3-7/8	.29	.30
856-010	856-010C	1	2-3/16	1-1/32	5/8	3-1/8	4	1/2	2-1/4	4-1/4	.39	.41
856-012	856-012C	1-1/4	2-11/32	1-3/32	11/16	3-1/2	4	1/2	2-1/4	4-5/8	.50	.50

PVC & CPVC INJECTION MOLDED CLASS 150 FLANGES



Flange Van Stone Style (continued)

(Two Piece)
Spigot

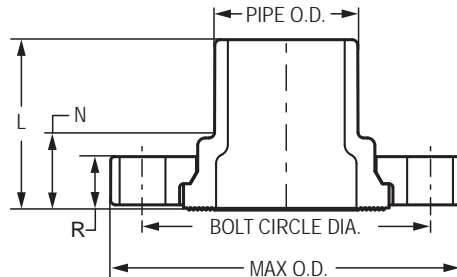

Part Number		Size	L	N	R	Bolt Circle Dia.	No. of Bolt Holes	Bolt Size	Min. Bolt Length	Max. O.D.	Approx. Wt. (Lbs.)	
PVC	CPVC										PVC	CPVC
856-015	856-015C	1-1/2	2-5/8	1-9/32	3/4	3-7/8	4	1/2	2-1/2	5	.60	.65
856-020	856-020C	2	2-7/8	1-11/32	13/16	4-3/4	4	5/8	3	6	.94	1.00
856-025	856-025C	2-1/2	3-1/16	1-9/32	1	5-1/2	4	5/8	3-1/4	7	1.29	1.54
856-030	856-030C	3	3-3/8	1-7/16	1-1/16	6	4	5/8	3-1/4	7-1/2	1.82	1.88
856-040	856-040C	4	3-7/8	1-5/8	1-1/4	7-1/2	8	5/8	3-1/2	9	2.93	3.12
856-060	856-060C	6	4-3/4	1-25/32	1-9/32	9-1/2	8	3/4	4	11	4.62	4.79
856-080	856-080C	8	5-7/8	1-15/16	1-3/8	11-3/4	8	3/4	4-1/2	13-1/2	7.95	8.17
856-100	856-100C	10	8	2-1/4	1-5/8	14-1/4	12	7/8	5	16	15.61	16.09
856-120	856-120C	12	8-1/2	2-3/16	1-5/8	17	12	7/8	5	19	21.31	22.70

Flange Van Stone Style

with Multi-Bolt Pattern Ring
(Two Piece)
Spigot

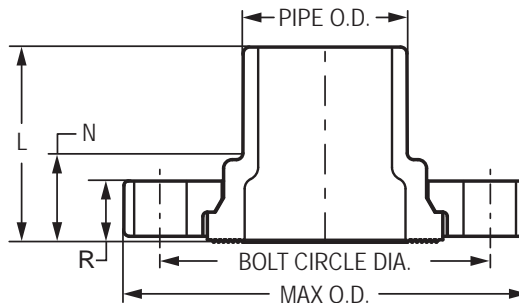

Part Number		Size	L	N	R	Bolt Circle Dia.		No. of Bolt Holes	Bolt Size	Max. O.D.	Approx. Wt. (Lbs.)	
PVC	CPVC					Min.	Max.				PVC	CPVC
M856-020	M856-020C	2	2-7/8	1-11/32	13/16	4-1/2	4-15/16	4	5/8	6	.94	1.00
M856-060	M856-060C	6	4-3/4	1-25/32	1-9/32	9-7/32	9-1/2	8	3/4	11	4.77	5.21
M856-080	M856-080C	8	5-7/8	1-15/16	1-3/8	11-1/2	11-3/4	8	3/4	13-1/2	7.95	8.32



PVC & CPVC FABRICATED IPS, PIP & CLASS 300 FLANGES

Technical Information

Application

Fabricated IPS and PIP Flange fittings are coupling devices designed for joining IPS (Iron Pipe Size) or PIP (Plastic Irrigation Pipe) plastic piping systems, where frequent disassembly may be required. These flanges can be used as transitional fittings for joining IPS-to-IPS, PIP-to-PIP, IPS-to-PIP, or plastic to metal piping systems. Suitability of application is at the discretion of the user.

Pressure Rating

All standard fabricated flanges are Van Stone Style (except blind flange) — two piece design with rotating flange ring.

Class 150 IPS Flanges (with steel ring): 150 psi, water at 73°F.

IPS Flanges 18" - 24" (with plastic ring): 50 psi, water at 73°F.

IPS Flanges, Class 300 Bolt Pattern (with plastic ring): 1/2" - 16" 150 psi, 18" - 24" 50 psi, water at 73°F.

Blind Flanges, 14" - 24": 50 psi, water at 73°F.

PIP Flanges, 6" - 16" (with plastic ring & molded IPS flanges w/PIP Adapters): 125 psi, water at 73°F

PIP Flanges, 18" - 24" (with steel ring): 125 psi, water at 73°F

Flange Types

Van Stone Style Class 150 IPS (with steel ring) — Fabricated PVC body with steel flange ring, available in sizes 18" through 24", slip socket and 14" through 24", spigot.

Van Stone Style IPS (with plastic ring) — Fabricated PVC body with PVC flange ring, available in sizes 18" through 24", slip socket and 14" through 24", spigot.

Van Stone Style PIP (with plastic ring) — PIP adapter fabricated to injection molded PVC Van Stone Style IPS flange, available in sizes 6" through 16", slip socket.

Van Stone Style PIP (with steel ring) — Fabricated PVC body with steel flange ring, available in sizes 14" through 24", slip socket.

Blind — Closed ring design for capping off a mating flange; fabricated PVC available in sizes 5" and 14" through 24".

Special Note On PIP Flange Sizes

In order to facilitate connections between IPS and PIP systems, all Plastic Irrigation Pipe flanges are fabricated with PIP sockets using standard IPS Flange Rings. These are indicated in dimension tables under "Size" as (nominal IPS flange size) x (actual PIP O.D.), such as: 6" x 6.140".

To better meet user needs, Spears® offers flanges for 15.300" O.D. PIP with either 14" or 16" IPS Flange Rings. In addition, both 18.360" and 18.701" O.D. PIP are offered with 18" IPS Flange Rings.

Materials

All fabricated flanges are produced from PVC & CPVC materials approved for potable water use by the National Sanitation Foundation (NSF).

Steel flange rings are carbon steel.

Conformance Standards

Materials — ASTM D 1784 (PVC Cell Classification 12454-B, CPVC Cell Classification 23447-B).

PVC & CPVC FABRICATED IPS, PIP & CLASS 300 FLANGES



Weights & Dimensions

Specified minimum bolt lengths are based on the use of two Spears® Flanges, two standard flat washers, standard nut and 1/8" thick elastomer full face gasket. Mating with other brands or accessories may require variations.

Note: Bolts and gaskets are not supplied with flanges.

Dimension references:

L = Overall length of hub, ± 1/2 inch.

M = Outside diameter of socket hub, ± 1/4 inch.

N = (Laying Length) socket bottom to seal-ring face of flange, ± 1/2 inch.

R = Height (thickness) of flange ring, ± 1/16 inch.

Max O.D. = Outside diameter of ring, ± 1/16 inch.

Bolt Circle Diameter = ANSI B16.5 Standard; ASTM D 4024, ± 1/16 inch.

Flange Van Stone Style PIP

(with Plastic Ring)

Socket

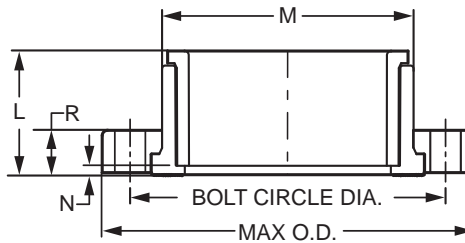

Part Number	Size	L	M	N	R	Bolt Circle Dia.	No. of Bolt Holes	Bolt Size	Min. Bolt Length	Max O.D.	Approx. Wt. (Lbs.)
354-060F	6x6.140	4-1/16	7-9/16	11/16	1-1/4	9-1/2	8	3/4	4	11-1/2	5.53
354-080F	8x8.160	4-15/16	9-3/8	9/16	1-1/2	11-3/4	8	3/4	4-1/2	13-5/8	8.30
354-100F	10x10.200	6-1/4	11-3/4	1	1-5/8	14-1/4	12	7/8	5	16	14.49
354-120F	12x12.240	7-5/16	13-11/16	1-1/16	1-5/8	17	12	7/8	5	19	21.59
354-151F	16x15.300	8-11/16	17-3/4	11/16	2-3/8	21-1/4	16	1	6-1/2	23-1/2	66.06

Flange Van Stone Style PIP

(with Plastic Ring)

Socket

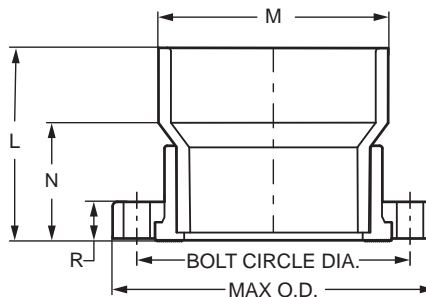

Part Number	Size	L	M	N	R	Bolt Circle Dia.	No. of Bolt Holes	Bolt Size	Min. Bolt Length	Max O.D.	Approx. Wt. (Lbs.)
354-150F	14x15.300	19-5/16	16-3/16	10-5/16	2	18-3/4	12	1	5-1/2	21	47.29



PVC & CPVC FABRICATED IPS, PIP & CLASS 300 FLANGES

Flange Van Stone Style PIP

(with Steel Ring)

Socket

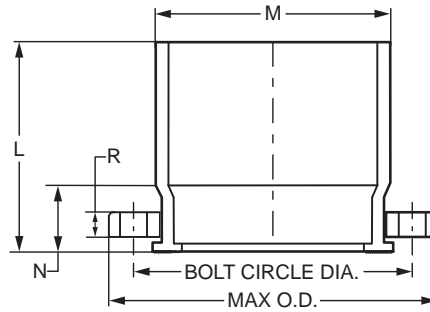

Part Number	Size	L	M	N	R	Bolt Circle Dia.	No. of Bolt Holes	Bolt Size	Min. Bolt Length	Max O.D.	Approx. Wt. (Lbs.)
354-181F	18x18.701	15-1/8	19-9/16	6-1/8	1/2	22-3/4	16	1-1/8	3	25	53.80
354-182F	18x18.360	11-5/8	19-1/4	5-5/8	1/2	22-3/4	16	1-1/8	3	25	53.80
354-200F	20x20.400	11-3/8	21-3/8	5-3/8	1/2	25	20	1-1/8	3	27-1/2	63.06
354-201F	20x22.047	16-9/16	23	6-9/16	1/2	25	20	1-1/8	3	27-1/2	64.43
354-241F	24x24.803	19-7/8	26	7-7/8	1/2	29-1/2	20	1-1/4	3	32	90.50

Blind Flange

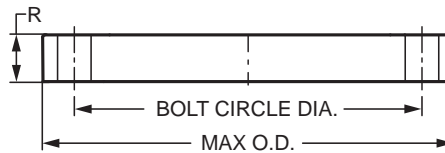

Part Number		Size	R	Bolt Circle Dia.	No. of Bolt Holes	Bolt Size	Min. Bolt Length	Max. O.D.	Approx. Wt. (Lbs.)	
PVC	CPVC								PVC	CPVC
853-050F	853-050CF	5	1	8-1/2	8	3/4	4-1/8	10-1/16	3.63	3.90
853-140F	853-140CF	14	1-1/2	18-3/4	12	1	4-1/8	21	27.50	28.39
853-160F	853-160CF	16	1-1/2	21-1/4	16	1	4-1/8	23-1/2	33.83	37.21
853-180F	853-180CF	18	1-1/2	22-3/4	16	1-1/8	4-1/8	25	39.52	43.47
853-200F	853-200CF	20	1-1/2	25	20	1-1/8	4-1/8	27-1/2	47.67	52.43
853-240F	853-240CF	24	1-1/2	29-1/2	20	1-1/4	5-1/2	32	61.96	68.15

PVC & CPVC FABRICATED IPS, PIP & CLASS 300 FLANGES



Flange Van Stone Style IPS

(with Plastic Ring)

Socket

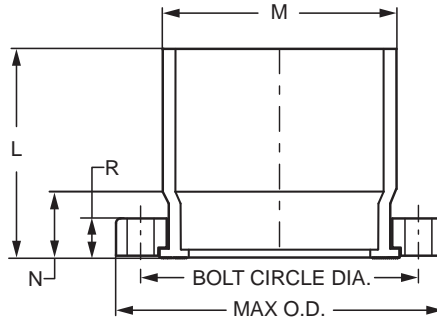

Part Number	Size	L	M	N	R	Bolt Circle Dia.	No. of Bolt Holes	Bolt Size	Min. Bolt Length	Max O.D.	Approx. Wt. (Lbs.)
854-180FP	18	15	18-7/8	6	1-1/2	22-3/4	16	1-1/8	4-1/8	25	36.09
854-200FP	20	16	21	6	1-1/2	25	20	1-1/8	5-1/2	27-1/2	43.61
854-240FP	24	19	25-3/16	7	1-1/2	29-1/2	20	1-1/4	5-1/2	32	72.95

Flange Van Stone Style IPS

(with Steel Ring)

Socket

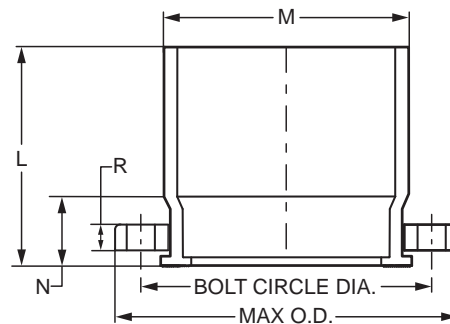

Part Number	Size	L	M	N	R	Bolt Circle Dia.	No. of Bolt Holes	Bolt Size	Min. Bolt Length	Max O.D.	Approx. Wt. (Lbs.)
854-180FS	18	14	18-7/8	5	1/2	22-3/4	16	1-1/8	3	25	49.30
854-200FS	20	15	21	5	1/2	25	20	1-1/8	3	27-9/16	65.00
854-240FS	24	18	25-3/16	6	1/2	29-1/2	20	1-1/4	3	32	86.15



PVC & CPVC FABRICATED IPS, PIP & CLASS 300 FLANGES

Flange Van Stone Style Class 300

(with Plastic Ring)

Socket

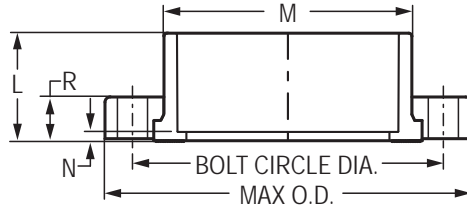

Part Number		Size	L	M	N	R	Bolt Circle Dia.	No. of Bolt Holes	Bolt Size	Min. Bolt Length	Max O.D.
PVC	CPVC										
854-005CL300	854-005CL300C	1/2	1	1-3/16	3/16	1/2	2-5/8	4	1/2	2	3-3/4
854-007CL300	854-007CL300C	3/4	1-1/8	1-3/8	3/16	1	3-1/4	4	5/8	3-1/2	4-5/8
854-010CL300	854-010CL300C	1	1-1/4	1-3/4	3/16	1	3-1/2	4	5/8	3-1/2	4-7/8
854-012CL300	854-012CL300C	1-1/4	1-3/8	2-1/8	1/8	1	3-7/8	4	5/8	3-1/2	5-1/4
854-015CL300	854-015CL300C	1-1/2	1-1/2	2-7/16	3/16	1	4-1/2	4	5/8	3-1/2	6-1/8
854-020CL300	854-020CL300C	2	1-11/16	2-15/16	3/16	1	5	8	5/8	3-1/2	6-1/2
854-025CL300	854-025CL300C	2-1/2	2	3-9/16	1/4	1	5-7/8	8	3/4	3-1/2	7-1/2
854-030CL300	854-030CL300C	3	2-1/8	4-1/4	1/4	1	6-5/8	8	3/4	3-1/2	8-1/4
854-040CL300	854-040CL300C	4	2-1/2	5-1/4	1/4	1-1/2	7-7/8	8	3/4	4-1/2	10
854-060CL300	854-060CL300C	6	3-7/16	7-9/16	3/8	1-1/2	10-5/8	12	3/4	4-1/2	12-1/2
854-080CL300	854-080CL300C	8	4-3/8	9-3/8	5/16	1-1/2	13	12	7/8	4-1/2	15
854-100CL300	854-100CL300C	10	5-11/16	11-3/4	5/8	1-1/2	15-1/4	16	1	4-1/2	17-1/2
854-120CL300	854-120CL300C	12	7-5/16	13-13/16	9/16	1-1/2	17-3/4	16	1-1/8	4-1/2	20-1/2
854-140CL300	854-140CL300C	14	7-9/16	15-9/16	9/16	2	20-1/4	20	1-1/8	5-1/2	23
854-160CL300	854-160CL300C	16	8-9/16	17-3/4	9/16	2	22-1/2	20	1-1/4	6	25-1/2

PVC & CPVC FABRICATED IPS, PIP & CLASS 300 FLANGES



Flange Van Stone Style Class 300 (continued)

(with Plastic Ring)

Socket

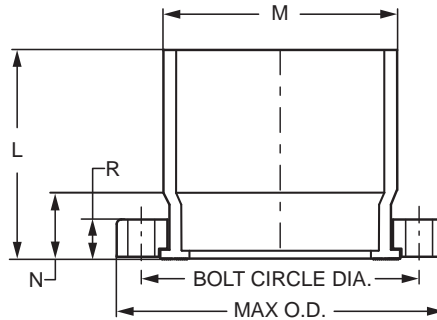

Part Number	Size	L	M	N	R	Bolt Circle Dia.	No. of Bolt Holes	Bolt Size	Min. Bolt Length	Max O.D.	Approx. Wt. (Lbs.)
854-180CL300	18	15	18-7/8	6	2	24-3/4	24	1-1/4	6	28	61.11
854-200CL300	20	15-1/4	21	5-1/4	2	27	24	1-1/4	6	30-1/2	68.38
854-240CL300	24	19	25-3/16	7	2	32	24	1-1/2	6	36	134.51

Flange Van Stone Style IPS

(with Plastic Ring)

Spigot

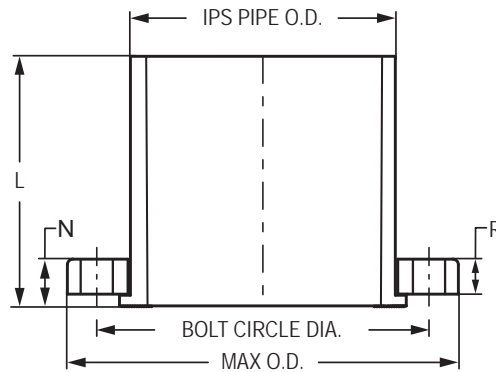

Part Number	Size	L	N	R	Bolt Circle Dia.	No. of Bolt Holes	Bolt Size	Min. Bolt Length	Max O.D.	Approx. Wt. (Lbs.)
856-140FP	14	15-5/16	7-9/16	2	18-3/4	12	1	5-1/2	21	24.00
856-160FP	16	17-13/16	8-9/16	2-3/8	21-1/4	16	1	6-1/2	23-1/2	61.83
856-180FP	18	19-9/16	9-9/16	2-3/8	22-3/4	16	1-1/8	6-1/2	25	34.81
856-200FP	20	13	2-1/16	1-1/2	25	20	1-1/8	5-1/2	27-1/2	42.50
856-240FP	24	16-3/8	2-1/8	1-1/2	29-1/2	20	1-1/4	5-1/2	32	68.00



PVC & CPVC FABRICATED IPS, PIP & CLASS 300 FLANGES

Flange Van Stone Style IPS

(with Steel Ring)
Spigot

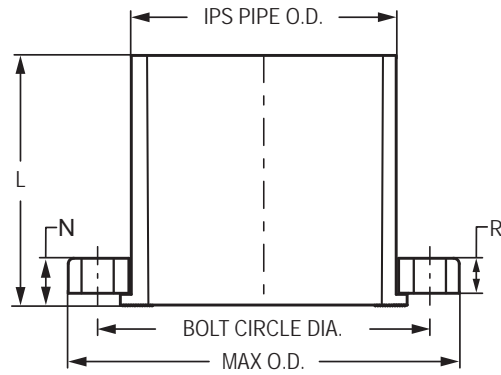

Part Number	Size	L	N	R	Bolt Circle Dia.	No. of Bolt Holes	Bolt Size	Min. Bolt Length	Max O.D.	Approx. Wt. (Lbs.)
856-140FS	14	10	15/16	1/2	18-3/4	12	1	3	21	36.63
856-160FS	16	11	1	1/2	21-1/4	16	1	3	23-1/2	46.50
856-180FS	18	12	15/16	1/2	22-3/4	16	1-1/8	3	25	47.27
856-200FS	20	13	1-1/16	1/2	25	20	1-1/8	3	27-1/2	59.00
856-240FS	24	15-3/8	1-1/8	1/2	29-1/2	20	1-1/4	3	32	84.00

NOTES

NOTES

Spears® Quality Policy

It is the policy and objective of Spears® Manufacturing Company to produce a superior quality product suitable for its intended use, with regard to functionality, structural integrity and conformance to established industry standards and practices. It is the commitment of this Company to do so in a manner which provides consistency of product quality, optimum availability, and superior customer service, while maintaining efficiency of operations and profitability necessary to perpetuate product improvement and customer satisfaction. Furthermore, it is recognized that the attainment of these objectives is the responsibility of all Company operations and personnel according to their respective functions.



SPEARS® MANUFACTURING COMPANY

Corporate Office

15853 Olden Street • Sylmar, CA 91342

PO Box 9203 • Sylmar, CA 91392

(818) 364-1611 • <http://www.spearsmfg.com>

